

(Fig 1) Send and Return Loop Jack

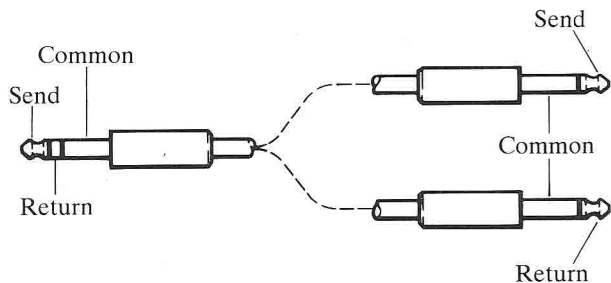

(Fig 2) Battery Installation and Removal

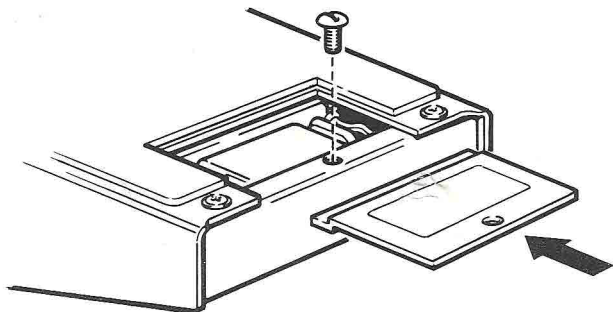

Use PP3 or equivalent battery

Jim Marshall (Products) Ltd, Denbigh Road, Bletchley, Milton Keynes, MK1 1DQ
Telephone: (0908) 375411. Fax: (0908) 376118. Telex: 826483 MARAMP-G.

The Guv'nor

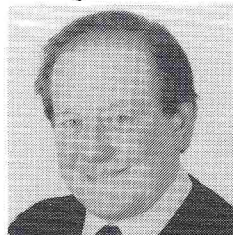

I would like to thank you personally for selecting the Marshall 'Guv'nor' overdrive pedal.

Our reputation is built on a total commitment to design and manufacture the finest units available in the world. To that end we have spared no effort in providing the best in material and precision workmanship to allow extended years of outstanding performance.

Please read the instructions overleaf carefully before operating your new pedal.

Again, thank you sincerely.

Jim Marshall
Managing Director

Marshall

1. Gain control

Adjusts the overall input sensitivity. Lower settings give cleaner sounds. Higher settings for more overdrive.

2. Bass control

Adjusts the low frequency 'bottom end' of the sound.

3. Middle control

Adjusts the mid range frequencies. High settings boost the mid for fatter sounds. Low settings cut the mid to give 'hollow' sounds.

4. Treble control

Adjusts the amount of upper harmonics (top end) in the sound.

N.B. The three tone controls inter-act and adjustment of one can allow a wider sound spectrum for the others to work on. A process of experimentation should provide your optimum settings.

5. Level control

Adjusts the overall output level allowing the user to balance the level of distorted sound to the level of the straight signal.

6. On/Off LED

Indicates when the pedal (and sub loop) is activated.

By-Pass Footswitch .7
Switches in the effect (and sub loop if in use).

Input Jack .8
Connects the instrument to the unit.

Send & Return Loop Jack .9
Allows the interconnection of further effects units with control from the switch on the Guv'nor. Use of this socket requires a lead wired as in the diagram (fig 1).

DC Input socket .10
Connects a standard 9 volt external DC power supply (not supplied) to the unit to eliminate the need for a battery. Note: Centre pin is Earth (0v), Outer ring is +9v.



Output Jack .11
Connects the pedal to the amplification system.

